

Introduction

This installation guide provides instructions for installation, startup and adjustment. To receive a copy of the instruction manual, contact your local Sales Office or view a copy at www.fisher.com. For further information refer to: Type 92C Instruction Manual, D100255X012.

PED Categories

This product may be used as a safety accessory with pressure equipment in the following Pressure Equipment Directive categories. It may also be used outside of the Pressure Equipment Directive using sound engineering practice (SEP) per table below. For information on the current PED revision see Bulletin: [D103053X012](#).

PRODUCT SIZE	CATEGORIES	FLUID TYPE
DN 15, 20 and 25 / NPS 1/2, 3/4 and 1	SEP	1

Specifications

Body Sizes and End Connection Style

See Table 1

Maximum Allowable Inlet and Pilot Supply Pressures⁽¹⁾

Grey Cast Iron: 17.2 bar / 250 psig
Steel and Stainless Steel: 20.7 bar / 300 psig

Regulator Pressure Drops

Minimum: 1.0 bar / 15 psig
Maximum Operating: 10.3 bar / 300 psig for outlet pressure settings equal to or below 3.4 bar / 50 psig; 13.8 bar / 200 psig for outlet pressure settings above 3.4 bar / 50 psig
Maximum Emergency:
Grey Cast Iron Construction: 17.2 bar / 250 psig
Steel and Stainless Steel Construction: 20.7 bar / 300 psig

Outlet Pressure Range⁽¹⁾

See Table 2

Maximum Outlet Pressures⁽¹⁾

Maximum Operating Outlet Pressure: 10.3 bar / 150 psig
Maximum Emergency Outlet (Casing) Pressure:
Grey Cast Iron Construction: 17.2 bar / 250 psig
Steel and Stainless Steel Construction: 20.7 bar / 300 psig

Loading Pressure For Pressure-Loaded Regulator⁽¹⁾

Maximum allowable loading pressure is 17.2 bar / 250 psig for grey cast iron construction and 20.7 bar / 300 psig for steel or stainless steel construction; the maximum allowable diaphragm differential pressure of 10.3 bar / 150 psig for grey cast iron, steel and stainless steel constructions must not be exceeded.

Proof Test Pressure

All Pressure Retaining Components have been proof tested per Directive.

Maximum Temperature Capabilities⁽¹⁾

Grey Cast Iron: 208°C / 406°F
Steel and Stainless Steel: 260°C / 500°F
Optional High-Temperature Steel or Stainless Steel Body: 343°C / 650°F

Installation



WARNING

Only qualified personnel should install or service a regulator. Regulators should be installed, operated and maintained in accordance with international and applicable codes and regulations and Emerson Process Management Regulator Technologies, Inc. instructions.

If the regulator vents fluid or a leak develops in the system, it indicates that service is required. Failure to take the regulator out of service immediately may create a hazardous condition.

Personal injury, equipment damage or leakage due to escaping fluid or bursting of pressure-containing parts may result if this regulator is overpressured or is installed where service conditions could exceed the limits given in the Specifications section, or where conditions exceed any ratings of the adjacent piping or piping connections.

To avoid such injury or damage, provide pressure-relieving or pressure-limiting devices (as required by the appropriate code, regulation or standard) to prevent service conditions from exceeding limits.

Additionally, physical damage to the regulator could result in personal injury and property damage due to escaping fluid. To avoid such injury and damage, install the regulator in a safe location.

1. The pressure/temperature limits in this installation guide or any applicable standard limitation should not be exceeded.

Type 92C

Table 1. Body Sizes and End Connection Styles

SIZE	BODY MATERIAL	
	Grey Cast Iron	Steel or CF8M Stainless Steel
DN 15, 20 or 25 / NPS 1/2, 3/4 or 1	NPT	NPT, CL150RF, CL300RF or PN 16/25/40

Table 2. Outlet Pressure Ranges

SPRING USAGE	OUTLET PRESSURE RANGE		SPRING COLOR
	bar	psig	
Standard use up to 260°C / 500°F	0.34 to 4.8	5 to 70	Green
	1.4 to 10.3	20 to 150	Red
High-pressure and/or High temperature over 250°C / 500°F	1.0 to 6.9	15 to 100	Unpainted
	5.5 to 17.2	80 to 250	Unpainted

Clean out all pipelines before installation of the regulator and check to be sure the regulator has not been damaged or has collected foreign material during shipping. For NPT bodies, apply pipe compound to the external pipe threads. For flanged bodies, use suitable line gaskets and approved piping and bolting practices. Install the regulator in any position desired, unless otherwise specified, but be sure flow through the body is in the direction indicated by the arrow on the body.

Note

It is important that the regulator be installed so that the vent hole in the spring case is unobstructed at all times. For outdoor installations, the regulator should be located away from vehicular traffic and positioned so that water, ice and other foreign materials cannot enter the spring case through the vent. Avoid placing the regulator beneath eaves or downspouts, and be sure it is above the probable snow level.

Overpressure Protection

The recommended pressure limitations are stamped on the regulator nameplate. Some type of overpressure protection is needed if the actual inlet pressure exceeds the maximum operating outlet pressure rating. Overpressure protection should also be provided if the regulator inlet pressure is greater than the safe working pressure of the downstream equipment.

Regular operation below the maximum pressure limitations does not preclude the possibility of damage from external sources or debris in the line. The regulator should be inspected for damage after any overpressure condition.

Startup

The regulator is factory set at approximately the midpoint of the spring range or the pressure requested, so an initial adjustment may be required to give the desired results. With proper installation completed and relief valves properly adjusted, slowly open the upstream and downstream shutoff valves.

Adjustment

To change the set pressure, remove the closing cap or loosen the locknut and turn the adjusting screw clockwise to increase outlet pressure or counterclockwise to decrease pressure. Monitor the outlet pressure with a test gauge during the adjustment. Replace the closing cap or tighten the locknut to maintain the desired setting.

Taking Out of Service (Shutdown)



WARNING

To avoid personal injury resulting from sudden release of pressure, isolate the regulator from all pressure before attempting disassembly.

Parts List

Regulator

Type 6392 Pilot

Key	Description	Key	Description
1	Regulator Body Assembly with bushing	1	Pilot Body
2	Diaphragm Flange	2	Spring Case
3	Orifice	3	Orifice
4	Valve Plug	4	Valve Plug
5	Valve Plug Guide	5	Valve Plug Guide
6	Stem Guide Bushing	6	Stem Assembly
7	Valve Plug Spring	7	Diaphragm
8*	Diaphragm	8*	Diaphragm Gasket
9*	Diaphragm Gasket	9	Lower Spring Seat
10	Pitot Tube	10	Stem Guide Bushing
11	Stem Assembly	11	Valve Plug Spring
12	Cap Screw	12	Strainer Screen
14	Drive Screw	13	Control Spring
15	Diaphragm Ring Regulator	14	Upper Spring Seat
		15	Jam Nut
		16	Adjusting Screw
		17	Cap Screw
		26	Valve Plug Cap

*Recommended spare part.

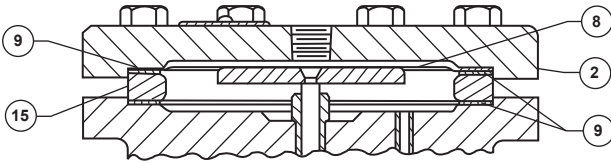

26A1538-A

STEEL/STAINLESS STEEL CONSTRUCTION

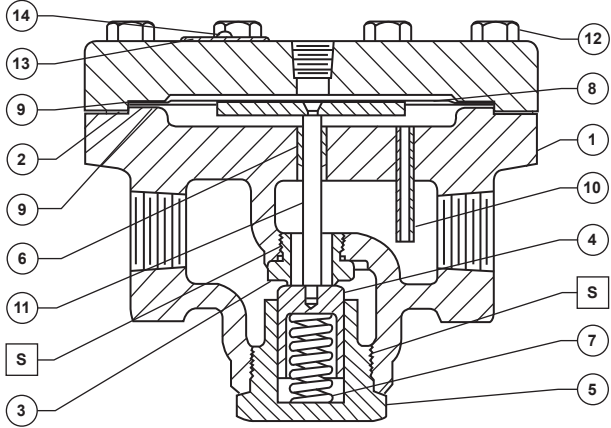

26A1538-A

GREY CAST IRON CONSTRUCTION

□ APPLY SEALANT:
S = ANTI-SEIZE COMPOUND

Figure 1. Type 92C Steam Regulator Assembly

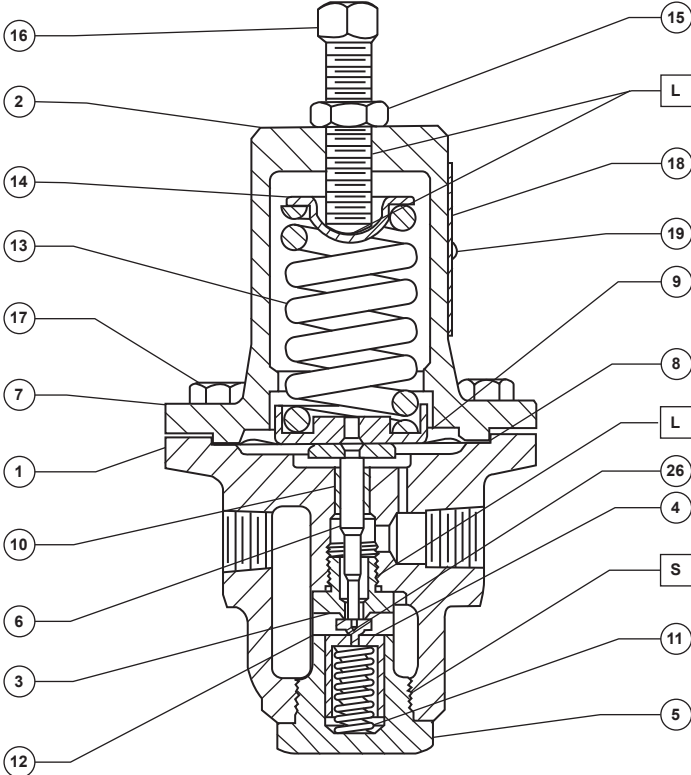

16A1520-B
□ APPLY LUBRICANT/SEALANT:
L = ANTI-SEIZE LUBRICANT
S = ANTI-SEIZE COMPOUND

Figure 2. Type 6392 Pilot Assembly

Type 92C

✉ Webadmin.Regulators@emerson.com

🔍 Fisher.com

📘 Facebook.com/EmersonAutomationSolutions

🌐 LinkedIn.com/company/emerson-automation-solutions

🐦 Twitter.com/emr_automation

Emerson Automation Solutions

Americas

McKinney, Texas 75070 USA
T +1 800 558 5853
+1 972 548 3574

Europe

Bologna 40013, Italy
T +39 051 419 0611

Asia Pacific

Singapore 128461, Singapore
T +65 6777 8211

Middle East and Africa

Dubai, United Arab Emirates
T +971 4 811 8100

D100255X014 © 2002, 2018 Emerson Process Management Regulator Technologies, Inc. All rights reserved. 10/18.

The Emerson logo is a trademark and service mark of Emerson Electric Co. All other marks are the property of their prospective owners. Fisher™ is a mark owned by Fisher Controls International LLC, a business of Emerson Automation Solutions.

The contents of this publication are presented for information purposes only, and while effort has been made to ensure their accuracy, they are not to be construed as warranties or guarantees, express or implied, regarding the products or services described herein or their use or applicability. All sales are governed by our terms and conditions, which are available on request. We reserve the right to modify or improve the designs or specifications of our products at any time without notice.

Emerson Process Management Regulator Technologies, Inc does not assume responsibility for the selection, use or maintenance of any product. Responsibility for proper selection, use and maintenance of any Emerson Process Management Regulator Technologies, Inc. product remains solely with the purchaser.



For further information on the current PED revision see Bulletin: [D103053X012](#) or scan the QR code.

