

NEOTECHA SAPRO[®] SAMPLING VALVE SV FOR SAMPLING WITH PISTON SYRINGES
 INSTALLATION AND MAINTENANCE INSTRUCTIONS

Before installation these instructions must be fully read and understood

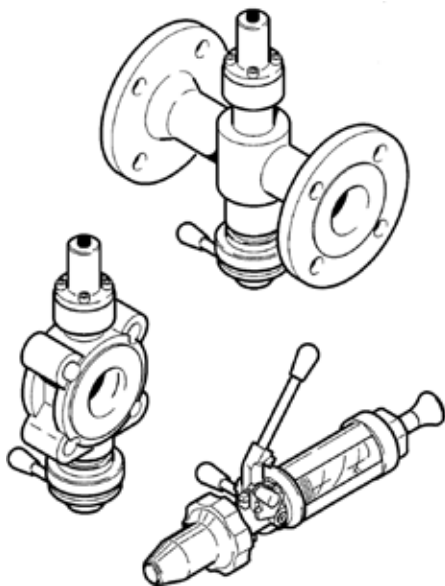

1 GENERAL INFORMATION

These installation and maintenance instructions contain the information necessary for safe and correct installation and operation of the valve in the prescribed manner. If any difficulties are encountered during installation or operation which cannot be solved with the aid of the installation and maintenance instructions, please contact the supplier/manufacturer for more information. These installation and maintenance instructions comply with the relevant applicable EN safety standards.

When installing the valve, the operator or the person responsible for the design of the installation must ensure that applicable national regulations are complied with. The manufacturer reserves all rights to make technical changes and improvements at any time.

The use of these installation and maintenance instructions assumes that the user is qualified to 'Qualified Personnel' level. Operating staff must be given appropriate training in the operating and maintenance instructions.

1.1 Validity of the installation and maintenance instructions

These installation and maintenance instructions are valid for all SAPRO sampling valves for sampling into piston syringes, which have been manufactured since 28 November 2001 by the Neotecha AG company. The validity is only guaranteed until the next revision change!

2 SAFETY

Please read these notes carefully.

2.1 General potential danger due to:

- a. failure to observe the instructions
- b. improper use
- c. insufficiently qualified personnel

2.2 Correct use

2.2.1 Area of application

SAPRO sampling valves are valves which allow a precisely measured sample of highly corrosive, hot liquids and gases to be taken. A special feature of the SV is the interchangeable soft seal, which can be supplied in TFM or Perfluorelastomer, depending on the medium used, together with the different body, adaptor and operating element variants.

The SV is suitable for vertical mounting and also, subject to certain restrictions, for horizontal mounting. When the valve is installed horizontally, it must always be ensured that the pipe is filled with sufficient medium, so that a representative sample can be taken.

All product-wetted components are manufactured in PFA/PTFE/TFM materials or in stainless high-grade steel.

The materials used for components under pressure are Mat. Nos. 1.4581, 1.0425, 1.4435, 1.4541. Depending on the medium, other materials, various types of Hastelloy, for example, can also be used.

2.2.2 Method of operation

The valve spindle seals against the sampling adaptor in the soft seat. Before and during the spindle is lifted it must be ensured that the media pressure and temperature are in the maximum allowable specification according

to the pressure and temperature diagram. When the spindle is lifted by the plunger of the piston syringe, the spindle opens the outlet and the medium flows into the cylinder of the piston syringe. The air in the syringe is compressed, but this does not present a problem, as the volume of air concerned is not very large. When the valve spindle is closed, the SAPRO sampling valve behaves almost like a continuous section of pipe, because of the specially adapted shape of the body. Very low friction losses and turbulence due to the valve spindle are to be expected.

NEOTECHA SAPRO® SAMPLING VALVE SV FOR SAMPLING WITH PISTON SYRINGES

INSTALLATION AND MAINTENANCE INSTRUCTIONS

PRESSURE - TEMPERATURE DIAGRAM (VALVE)

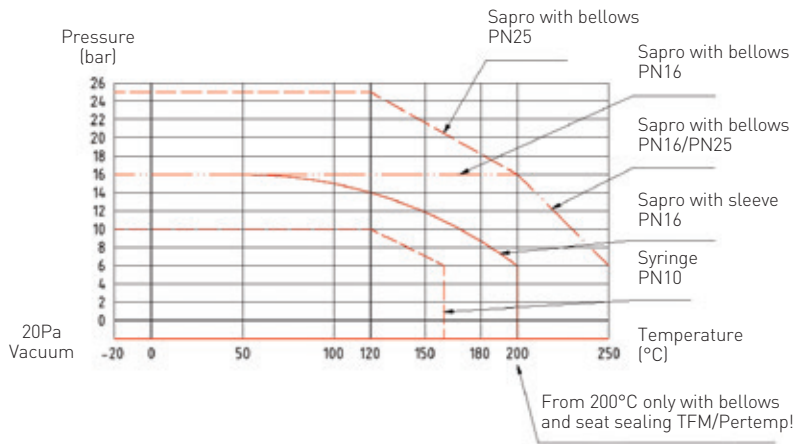

2.2.3 Performance data

Pressure range: 20Pa vacuum to 16 bar, the syringe can only be pressurized up to 10 bar, because of the glass cylinder!

Temperature range: See diagram

Nominal diameters: DIN PN 16
DN 15 - 100

Nominal diameters: ANSI Class 150
NPS ½ - 4

Test pressure - body: 1.5 x PN = 24 bar

Test pressure - syringe: 1.5 x PN = 15 bar

2.2.4 Usage restrictions

The product-wetted components must be classified as resistant to the product to be conveyed. Refer to appropriate literature or consult the manufacturer or distributor for advice.

2.2.5 Modification prohibition

Mechanical modifications to the valves or the use of other manufacturers' parts for repair purposes are not permissible. Safety is not guaranteed if this requirement is disregarded. Repair work must only be carried out by the manufacturer's trained personnel.

2.2.6 Warning about foreseeable misuse

Valves and their accessories must not be misused as climbing aids.

2.2.7 Duty to comply with the instructions for operation, maintenance and servicing

These operating instructions are part of the delivery package and must be kept clean and made accessible to the user.

2.3 Sources of danger

2.3.1 Chemical external

The steel/PFA bodies of the DN 65 - 100 valves are made from mechanically processed steel coated with a 2-part polyester paint. The coating can be attacked externally by strong solvents, leading to corrosion of the body. If damage of this nature occurs, the effects on the environment should be investigated and the damage to the coating made good.

2.3.2 Electrical

If static charges can lead to explosions, the valve must be earthed by means of the earthing accessory.

Alternative: use valves with electrically conductive linings. Please contact your supplier!

2.3.3 Thermal

Due to the range of operating temperatures between -20°C and +200°C, surface temperatures from -20°C to over +200°C can be present on the valve body. Suitable precautions should be taken at the installation stage to protect against burns due to high or freezing temperatures. Insulated gloves should be worn when using the valve.

In case of fire, the mechanical strength of the PFA coatings is no longer guaranteed above 250°C.

2.3.4 Protection against inadvertent opening of the sampling valve

The SAPRO sampling valve for sampling with the piston syringe can only be opened by the attached piston syringe; under normal circumstances, it is impossible for the valve to remain open when the syringe is detached.

2.4 Qualified personnel

This means people who are familiar with the erection, installation, commissioning, operation and maintenance of the product and have appropriate qualifications relating to their activities and functions, such as, for example:

- Instruction in and duty to comply with all installation-related, regional and internal works regulations and requirements.
- Training or instruction in accordance with the Safety Standards for personal care and use of appropriate safety equipment and protective workgear, like, for example, personal protection equipment (insulated gloves or similar), suitable for the operating conditions.

Furthermore, these people must have read and understood these instructions.

NEOTECHA SAPRO® SAMPLING VALVE SV FOR SAMPLING WITH PISTON SYRINGES

INSTALLATION AND MAINTENANCE INSTRUCTIONS

3 TRANSPORT/STORAGE

The valve is supplied with protective covers. Do not remove the protective covers until immediately prior to installation. They protect the PFA surfaces from dust and mechanical influences.

3.1 Transport

- Transport temperature -20°C to +65°C.
- Protect against external force (impact, shock, vibration).
- Do not damage the coating.

3.2 Storage

- Storage temperature -20°C to +65°C, dry and dust-free.
- A drying agent or heating is required in damp storage areas to protect against condensation.

3.3 Handling prior to installation

- Do not remove the protective caps until immediately prior to installation.
- Protect against the effects of weather, such as dampness, (or else use a drying agent).
- Proper treatment prevents damage.

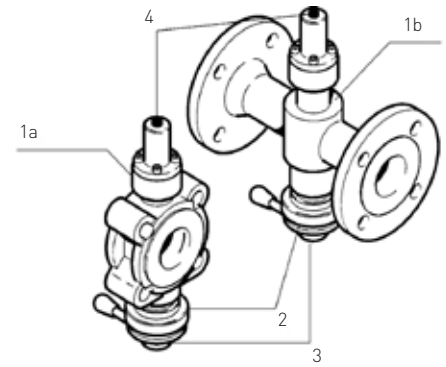

Figure 1

4 FEATURES

4.1 General features

Flange drillings	DIN 2501-1 PN16 ANSI B16.5 Class 150 Other drillings (PN25/40, ANSI Class 300) are available on request
Body variants	Wafer type Flanged to DIN standard Flanged to ANSI standard
Bolted joint	A2 bolt quality for all bolts subjected to pressure
Adaptor variants	Bayonet adaptor for sampling with piston syringes
Operating element variants	Piston syringe (the spindle is lifted by the plunger of the piston syringe)
Weights	The values given in the following table are only approximate, as the weight can vary additionally, because of the different adaptor and operating element variants.

4.1.1 Sampling valve for sampling with piston syringes (Figure 1)

- 1a. SAPRO sampling valve wafer type face-to-face dimension (DIN/ANSI).
- 1b. SAPRO sampling valve flanged face-to-face dimension (DIN or ANSI).
- 2. Bayonet coupling.
- 3. Blanking plug.
- 4. Lift indicator.

WEIGHTS

DN	NPS	Weight compact design	Weight flanged face to face
25	1	4.0	6.5
40	1½	5.1	8.7
50	2	6.1	10.6
65	2½	8.7	16.0
80	3	10.0	18.0
100	4	13.7	20.0

NEOTECHA SAPRO® SAMPLING VALVE SV FOR SAMPLING WITH PISTON SYRINGES

INSTALLATION AND MAINTENANCE INSTRUCTIONS

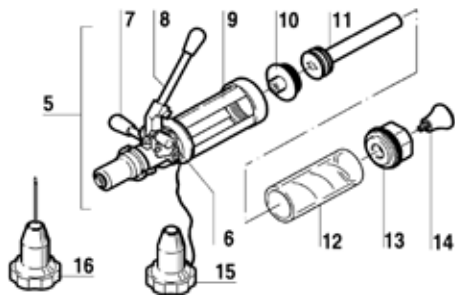

Figure 2

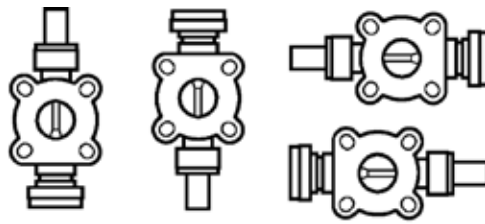

Figure 3

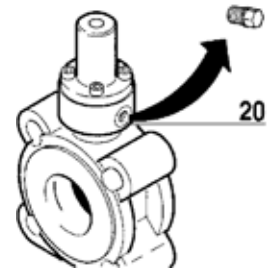

Figure 4

4.1.2 Piston syringe

- 5. SAPRO piston syringe
- 6. Safety lever
- 7. Auxiliary lever
- 8. Operating lever
- 9. Cylinder cap
- 10. Cylinder base with O-ring
- 11. Piston
- 12. Cylinder
- 13. Cylinder cap
- 14. Piston button

4.2 Installation position

4.2.1 Installation of sampling valve for sampling with piston syringes (Figure 3)

The sampling valve for sampling with piston syringes can be installed in any position. However, when the valve is installed horizontally or upside down, it must be ensured that the pipeline is filled with sufficient medium to ensure that a representative sample is taken.

4.3 Sealing

The sealing of the sampling valve at the bayonet coupling is assured by the soft seat seal; at the opposite side (spring cap), a metal bellows is used.

The soft seat seal can be removed with a special tool and replaced (the pipeline must be depressurized and drained!); in the event that the bellows starts to leak, the valve must be removed from the pipeline and sent in to the manufacturer.

Leakage past the bellows can be safely inspected via the leakage test hole (Figure 4, Item 20) on the upper neck of the valve, and therefore it is recommended that the yellow plastic screwed plug fitted for shipping is removed, and replaced, if possible, by screwing in a sensor. Never seal the tapped hole with a steel screwed plug!

5 IDENTIFICATION

CE identification on the valve, only if the product falls under the Pressure Equipment Directive 97/23/EC.

- The piston syringe has a smaller rating plate on which only the manufacturer, syringe type and serial number are stated (no CE mark, as, according to the Pressure Equipment Directive, the volume of the syringe is too small to be included in a category).

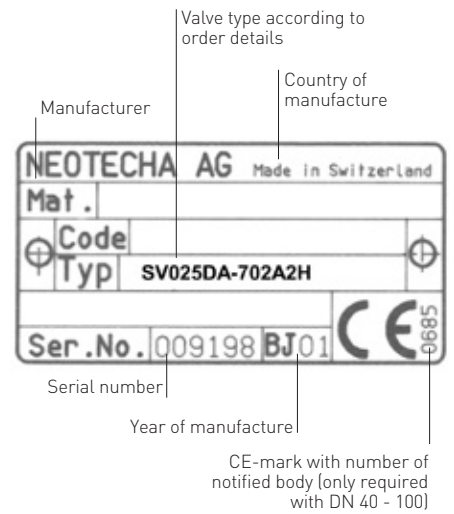

NEOTECHA SAPRO® SAMPLING VALVE SV FOR SAMPLING WITH PISTON SYRINGES

INSTALLATION AND MAINTENANCE INSTRUCTIONS

6 INSTALLATION

6.1 Installation

6.1.1 Preparation for installation

The dimensions of the valves have been chosen so that the sampling valves can be clamped between all current DIN and ANSI flanges. It should be noted here that sampling valves designed for a specific flange standard no longer fit other flanges.

Principal dimensions of the valves: refer to the catalog page for data.

The flanges must meet the following requirements:

- Cleaned and undamaged mating surface.
- The mating sections in the pipeline must be to the same connection standard as the valve which is to be installed.
- The appropriate flange bolt hole arrangements in the various flange standards and diameters allow the valve to be centered by passing the flange bolts through the holes in the flanges.
- The flange bolts must be centrally aligned in the holes in the valve flanges.

6.1.2 Installation position

In accordance with Section 4.2.1 of these installation and maintenance instructions, the sampling valve can be installed either horizontally or vertically, with certain restrictions (an angle adaptor is required for horizontal installation).

6.2 Installation in the pipeline

The direction of flow is irrelevant with the sampling valves. However, before the valve is installed, a check should be made on whether any special valve packings are required; for more information see Section 6.2.3.

An SV is not a crowbar! Please do not use it to force the flanges apart, as this would lead to damage to the PFA coating and the seat. To avoid damaging the PFA coating, the protective covers should only be removed immediately prior to installation.

WARNING

It is not advisable to use the valves for positioning pipelines in new systems. Sparks which occur during spot welding can damage the PFA coating. Use adjusting pieces instead. Final welding of the flange with the valve in position will lead to severe damage to the mounting flange due to the high temperature.

Always use all flange bolts, even on low pressure systems. The valve should never be pressurized if one of the four flange bolts is missing.

6.2.1 Step-by-step installation (Figure 5, 6)

1. Remove the plastic protective caps.
2. Check the mounting flanges (Items 11 and 12) for damage and soiling.
3. Check that the distance between flanges matches the face-to-face dimension of the sampling valve. Before installing the valve (Items 1a and 1b), spread the flanges apart sufficiently using a suitable tool.
4. Slide the valve between the opened flanges, and at the same time insert the packings (Item D, if required, see Section 6.2.4) between the sealing surfaces.
5. Now insert the flange bolts through the adjusting holes.
6. Tighten the flange bolts hand-tight as the tool holding the flanges apart is gradually removed. Make sure that the flanges remain correctly aligned.
7. Tighten all flange bolts in opposite pair sequence. See Section 6.2.2 for tightening torques.

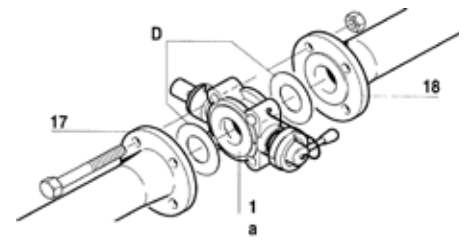

Figure 5

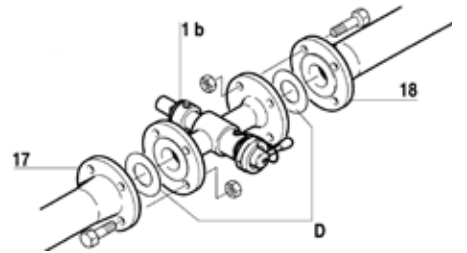

Figure 6

NEOTECHA SAPRO® SAMPLING VALVE SV FOR SAMPLING WITH PISTON SYRINGES

INSTALLATION AND MAINTENANCE INSTRUCTIONS

6.2.2 Recommended tightening torques (Nm) of bolted connections for installing SAPRO valves

STANDARD VALUES FOR GALVANIZED STEEL BOLTS (8.8), LIGHTLY OILED

DN	NPS	Torque high grade steel	Torque PFA
25	1	35	22
40	1½	60	35
50	2	100	55
65	2½	130	70
80	3	90	50
100	4	105	60

6.2.3 Final checks

Before commissioning the sampling valve, the pipeline should be flushed, to flush out any solid particles that might be present and which could damage the soft seat of the valve.

6.2.4 Packings

The SAPRO valves are installed and sealed like other valves (ball valves, butterfly valves, etc.).

First of all, take any internal works standards into account and use standard packings.

Depending on the type of pipeline, we recommend the following packings:

SAPRO valve	Pipeline type	Packing type	Packing material
High-grade steel wafer or flanged style	Steel or high-grade steel with flush flanges	Punched flat packing	Asbestos-free sheet
		Coated flat packing	PTFE casing with AFM liner
		GORE-TEX flat packing	Spun PTFE
PFA coated wafer or flanged style	Steel pipe enameled	Coated flat packing	PTFE casing with steel corrugated ring
	Steel PTFE lined	No packing	
	PVDF pipe	Punched flat packing	EPDM, IIR
	Steel pipe rubberized	Coated flat packing	PTFE casing with AFM liner
	Glass pipe with flat surface	GORE-TEX flat packing	Spun PTFE

7 COMMISSIONING

7.1. General commissioning

Before commissioning, the information relating to material, pressure and temperature should be checked against the installation diagram of the pipeline system.

Any debris left in the pipeline and valves (dirt, welding beads, etc.) will inevitably lead to leakage.

WARNING

Before each commissioning of a new system or re-commissioning of a system after repair or modification, it must be ensured that:

- All installation and assembly work has been completed in accordance with the regulations!
- Commissioning is only undertaken by 'Qualified personnel'.
- The valve is in the correct operating position.
- New protective equipment is installed or existing protective equipment repaired.

8 SAFE OPERATION

Safe operation of the valve is only guaranteed if it has been correctly installed, commissioned and maintained by qualified personnel (see 'Qualified personnel'), taking into account the warning information of these installation and maintenance instructions. In addition, compliance with the general installation and safety regulations for the pipeline or plant construction, together with the correct use of tools and protective equipment, must be ensured.

WARNING

The installation and maintenance instructions must be strictly followed when any work is carried out on the valve or when handling the valve. Non-observance can result in injuries or damage to property.

NEOTECHA SAPRO® SAMPLING VALVE SV FOR SAMPLING WITH PISTON SYRINGES

INSTALLATION AND MAINTENANCE INSTRUCTIONS

9 OPERATION

9.1 Attaching the piston syringe to the sampling valve

1. Before using the piston syringe (Item 5), make sure that the cylinder (Item 12) in the cylinder cage (Item 9) is tightly sealed with the cover (Item 13), and that the piston rod (Item 11) is in the retracted position.
2. Detach the blanking plug (Item 3) on the SAPRO sampling valve by turning the lever in the direction of the arrow (a), and then pulling the plug out of the bayonet coupling (Item 2) in direction (b).
3. Set the safety lever (Item 6) on the syringe to the normal position (A)
4. Align the operating lever (Item 8) so that the markings (M) on the bayonet coupling and the lever coincide.
5. Introduce the piston syringe (Item 5) into the bayonet coupling (Item 2) and then, using the auxiliary lever (Item 7), turn it in the direction of the arrow, as far as the stop.
6. Set the safety lever (Item 6) to position B, in accordance with the direction of the arrow. This locks the bayonet coupling (Item 2) on the sampling valve and releases the operating lever (Item 8).

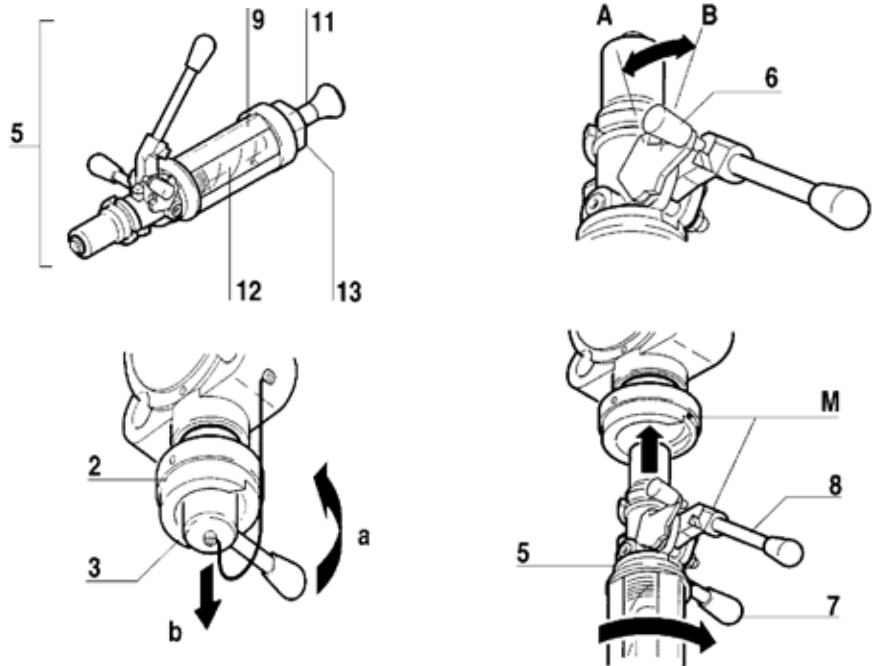

9.2 Sampling

The following options are available for sampling

9.2.1 With pressurized pipelines (Figure 7)

1. Press the operating lever (Item 8) in the direction of the arrow. The valve and piston syringe are opened. The piston of the cylinder is automatically pressed backwards by the pipeline pressure, and the medium flows into the cylinder.
2. Release the operating lever (Item 8). Because of the spring loading, the operating lever automatically travels back to the initial position. Consequently, the sampling valve and the piston syringe close.

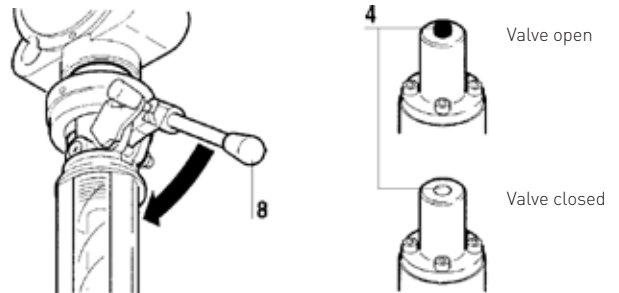

Figure 7

WARNING

*Always take note of the lift indicator (Item 4) before detaching the piston syringe!
When the valve is closed, the lift indicator must fully retract into the spring cover!
If this is not the case, the sampling valve is not tightly sealed, and the medium can leak out when the piston syringe is detached!*

NEOTECHA SAPRO® SAMPLING VALVE SV FOR SAMPLING WITH PISTON SYRINGES

INSTALLATION AND MAINTENANCE INSTRUCTIONS

9.2.2 With non-pressurized pipelines or pipelines under vacuum (Figure 8, 9)

1. Press the operating lever (Item 8) in the direction of the arrow.
2. Turn the safety lever (Item 6) to position C. The operating lever (Item 8) is now locked in the depressed position.
3. Draw the piston rod (Item 3) outwards, until the required quantity of the medium has entered the cylinder.
4. Press lightly on the operating lever (Item 8) and set the safety lever (Item 6) to position B again.
5. Release the operating lever. Because of the spring loading, the operating lever automatically travels back to the initial position. Consequently, the sampling valve and the piston syringe close.

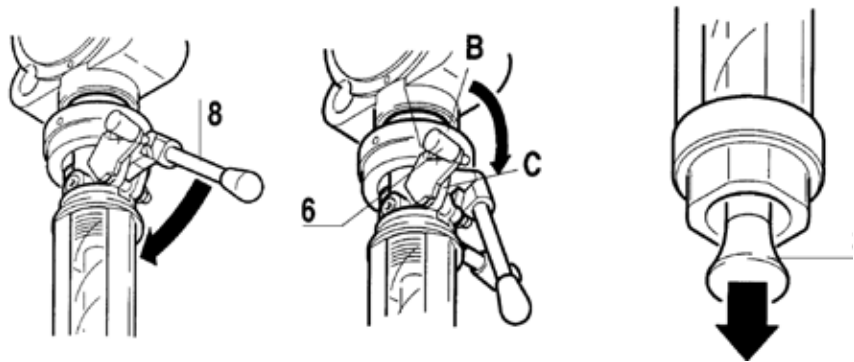

Figure 8

WARNING

Always take note of the lift indicator (Item 4) before detaching the piston syringe!
 When the valve is closed, the lift indicator must fully retract into the spring cover!
 If this is not the case, the sampling valve is not tightly sealed, and the medium can leak out when the piston syringe is detached!

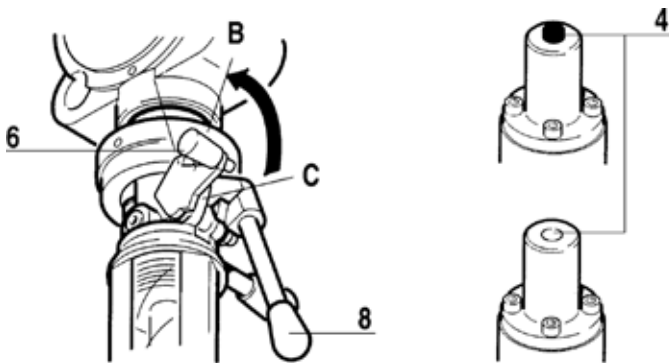

Figure 9

9.3 Detaching the piston syringe (Figure 10)

1. Perform a controlling movement of the operating lever (Item 8) in the direction of the arrow (a).
2. Set the safety lever (Item 6) to position A.
3. Using the auxiliary lever (Item 7), turn the piston syringe according to arrow (b) and pull it out of the bayonet coupling (Item 2) in direction (c).
4. Fit the blanking plug (Item 15) on the piston syringe (Item 5) and lock it in position by turning it in arrow direction (d).
5. Insert the blanking plug (Item 3) into the bayonet coupling (Item 2) and lock it in position by turning it in arrow direction (e).

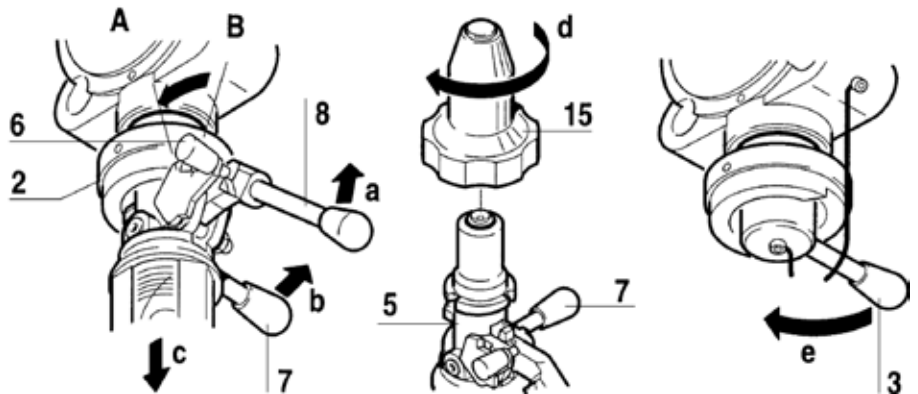

Figure 10

NEOTECHA SAPRO® SAMPLING VALVE SV FOR SAMPLING WITH PISTON SYRINGES

INSTALLATION AND MAINTENANCE INSTRUCTIONS

9.4 Decanting the contents of the piston syringe into a container (Figure 11)

WARNING

Always wear protective equipment when decanting aggressive or dangerous media. Observe the safety regulations for handling dangerous media!

1. Unscrew the blanking plug (Item 15) by turning in the direction of the arrow and detach it from the piston syringe (Item 5).
2. Fit the cap with the hollow needle (Item 16) on the piston syringe and lock it in position by turning it in the opposite arrow direction.

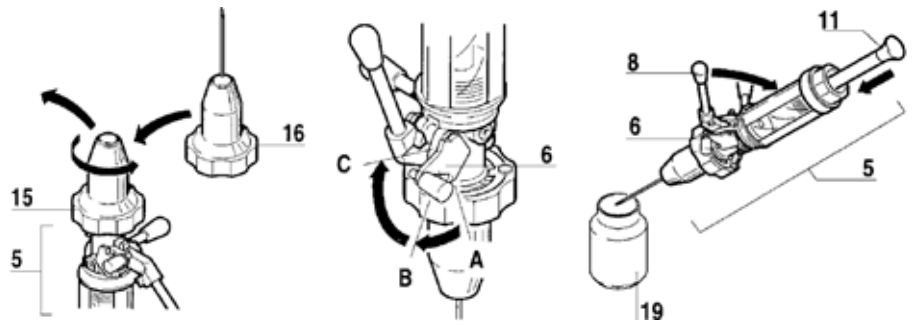
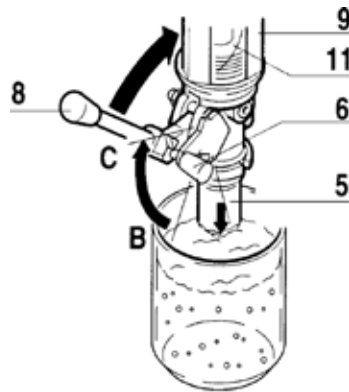

Figure 11

WARNING

Every care must be taken when setting up and operating the piston syringe with the hollow needle, to avoid injury to the operator!

3. Position the piston syringe with the hollow needle downwards into the container (Item 19).
4. Set the safety lever (Item 6) to position B.
5. Press the operating lever (Item 8) in the direction of the arrow and, using the safety lever (Item 6), lock it at position C.
6. Slowly press the piston (Item 11) inwards. The contents of the cylinder now flow through the hollow needle into the container (Item 19).



10 SERVICING AND CLEANING

No routine maintenance or lubrication is required. However, for systems with high temperatures, an inspection for leakage at the flanges should be carried out shortly after installation. The large difference between the temperature-related expansions of PFA and metals can result in cold flow. Tightening the bolts once again will rectify this problem. This process may possibly have to be repeated several times.

WARNING

Before any dismantling or maintenance work is carried out, the medium in the (depressurized!) pipeline must be drained off and the pipeline flushed, so that there is no longer any danger for the operator/fitter.

When sampling clean, liquid products, no cleaning is normally required. In any case, if the bayonet coupling or the piston syringe of the valve do become soiled (crystallizing medium), these parts can be dismantled and cleaned as follows:

- The bayonet coupling on the SAPRO sampling valve can easily be flushed out with a cleaning agent without any dismantling.

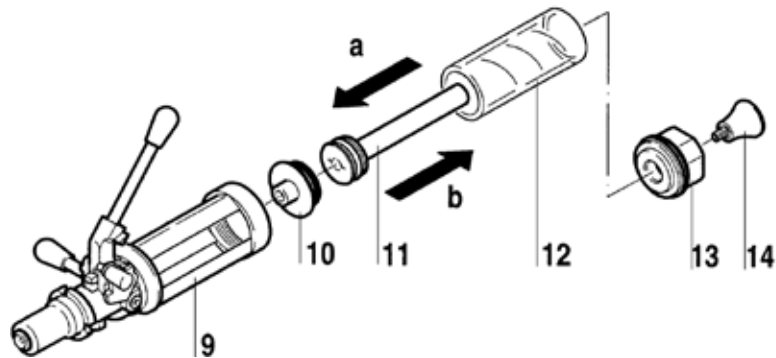

NEOTECHA SAPRO® SAMPLING VALVE SV FOR SAMPLING WITH PISTON SYRINGES

INSTALLATION AND MAINTENANCE INSTRUCTIONS

If the piston syringe is only lightly soiled, it can be cleaned in a glass using cleaning fluid without any dismantling, by immersing the nose of the syringe (Item 5) in the fluid and drawing the operating lever (Item 8) back after releasing the safety lever (Item 6). If the piston (Item 11) is pulled back and then pushed in again several times, the complete internal assembly of the piston syringe wetted by the medium will be flushed through and cleaned.

With heavier soiling, the piston syringe must be dismantled after an initial simple cleaning:

1. Unscrew the cap (Item 13).
2. Withdraw (b) the complete cylinder/piston unit (Items 11 - 14); all the components of this unit are screwed together and can be easily dismantled.
3. Dismantle the seal insert (Item 10).
4. Clean all individual components with cleaning fluid, check and lubricate the O-ring with silicon oil.
5. Reinstall (a) the insert and the cylinder/piston unit in the cylinder cage (Item 9) of the piston syringe.

Cleaning agents

The cleaning agents recommended by the internal works department should be used. Material compatibilities should be checked before cleaning starts.

11 TROUBLESHOOTING

If the valve function or operating action is faulty, a check should be made to ensure that the assembly and installation work has been carried out and completed in accordance with the installation and maintenance instructions. The information relating to material, pressure, temperature and direction of flow should be compared with the installation diagram of the pipeline system. Furthermore, a check should be made on whether the installation conditions correspond to the technical data given in the data sheet or on the rating plate.

WARNING

The safety regulations must always be observed when troubleshooting.

12 DECOMMISSIONING

Removal of the valve for repair or servicing is often carried out carelessly, as the valve has to be repaired or replaced in any case. However, it is recommended that the valve be removed with care, without damaging the PFA coating, so that the possible cause of damage can be determined after removal.

ATTENTION

Check that the pipe is depressurized and drained. With corrosive, inflammable, aggressive or toxic media, flush and ventilate the pipeline system.

1. Only allow assembly work to be carried out by Qualified personnel (see Section 2.4).
2. Loosen all flange bolts and withdraw them until the valve can be removed.
3. Spread the flanges apart using a suitable tool and withdraw the valve.

13 DISPOSAL

Hand in the correctly cleaned valve to the scrap material recycling plant.

WARNING

- *Badly cleaned valves can cause severe burning of the hands and other parts of the body.*
- *If the sampler is passed on to a third party, the manufacturer does not guarantee the safety of the equipment.*

Neither Emerson, Emerson Automation Solutions, nor any of their affiliated entities assumes responsibility for the selection, use or maintenance of any product. Responsibility for proper selection, use, and maintenance of any product remains solely with the purchaser and end user.

Neotecha is a mark owned by one of the companies in the Emerson Automation Solutions business unit of Emerson Electric Co. Emerson Automation Solutions, Emerson and the Emerson logo are trademarks and service marks of Emerson Electric Co. All other marks are the property of their respective owners.

The contents of this publication are presented for informational purposes only, and while every effort has been made to ensure their accuracy, they are not to be construed as warranties or guarantees, express or implied, regarding the products or services described herein or their use or applicability. All sales are governed by our terms and conditions, which are available upon request. We reserve the right to modify or improve the designs or specifications of such products at any time without notice.

Emerson.com/FinalControl