

Heater Products General Information

This section provides basic information for the design and selection for the proper Nelson heat trace products for pipe and vessel heating needs.

To specify components for an effectively designed, totally electric heat trace system, it is necessary to understand the basic principles involved. A heat trace system is designed to replace heat lost through the thermal insulation from equipment in the system. In some applications, heat tracing will also be able to provide enough heat to significantly change the process temperature.

Nelson always recommends the use of thermal insulation since heat loss from bare surfaces is very high and heat transfer between the heater and the pipe/vessel is highly variable. All insulation should be weatherproofed. Wet insulation is ineffectual and heater output is insufficient to dry it.

Nelson Heating Cable Products

Nelson supplies several distinctively different types of electric heaters - Self Regulating, Constant Wattage, Mineral Insulated. Each type has its own characteristics, often making one more suitable for a certain application than the others. It is important to determine which

Self Regulating Heater Cable

Self Regulating Heater Cable will adjust its own output in response to pipe temperature. Available in a variety of temperature and power ratings up to +230°C (+450°F) and 65.6w/m (20w/ft.). Product features include:

- Variable Output
 - Self-Regulating heaters will react to variations in temperature encountered at every point along its length. Colder sections receive more heat output, while warmer sections receive less. This provides greater energy efficiency and more uniform pipe temperatures.
- Can Be Overlapped Without Damage
 - Because Self-Regulating heaters controls its own output, overlapped sections produce less heat, eliminating “hot spots” and possible burn-through common with other types of cable.
- Fail Safe
 - Upon reaching the upper limits of its temperature range, Self-Regulating heaters diminishes its own heat output to an insignificant level. This guarantees that maximum temperatures (T ratings) cannot be exceeded no matter what product is used in any application.
- Easy Installation
 - Because of its infinite parallel path circuitry, Self-Regulating heaters can be cut to any length in the field without affecting the heat output or creating “dead zones”.

Constant-Wattage Heater Cable

Constant Wattage Heater Cable is a parallel resistance heater that produces the same watts-per-foot of heat along its entire length.

- Easy Installation
 - Constant-Wattage heaters can be cut to length and terminated in the field.
- Economical
 - Provides good power densities and exposure temperatures with parallel circuit cable capabilities at economical prices. Exposure Temperatures to +204°C (+400°F). Ideal for maintaining many process temperature applications.

Mineral Insulated Heater Cable

Mineral insulated Cable is a series conductor, high temperature heater cable with a special, thin metal sheath. Some of MI advantages are:

- Corrosion-Resistant
 - Alloy 825 sheath provides excellent corrosion resistance and immunity from chloride stress corrosion - a common problem with stainless steel.
- Ideal for High Temperature Applications
 - Mineral Insulated heaters can withstand exposure temperatures up to 593°C (1100°F).
- Ratings To 600V
 - Mineral Insulated heaters are available in a variety of voltages to match the available power supply.
- High Heat Output
 - Mineral Insulated heaters have heat output ratings up to 10 times higher than most other cables, reducing the amount of cable required.
- Rugged Construction
 - A durable metal sheath provides greater mechanical protection.
- Thin Wall Construction
 - A unique manufacturing process allows thin wall cable construction for easier field installation.

Design Considerations

Heat Trace Considerations

1. Types of Heater Control

There are two types of temperature control, ambient (air sensing) and line sensing. On small projects either of these types of control is achieved with individual component temperature controllers. On larger projects, it may be advantageous in terms of cost and maintenance, to use larger central control cabinets with electronic control.

Types of Heater Control

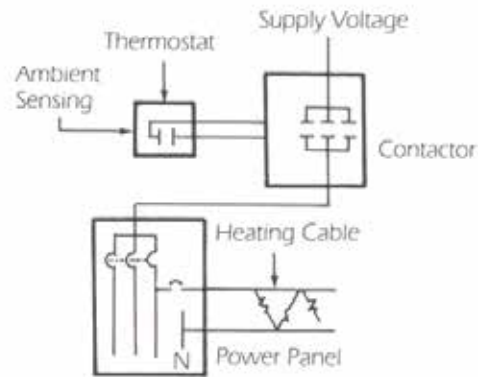
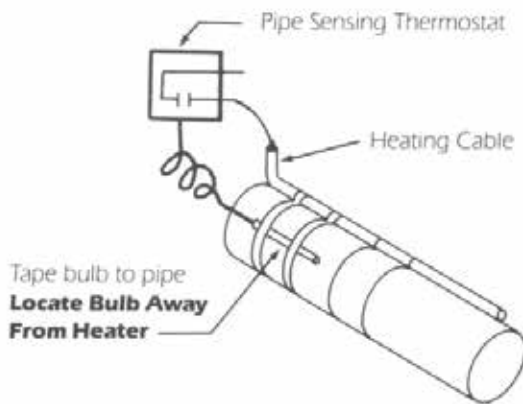

Line Sensing Control

Line sensing control means a thermostat or controller is used to sense each pipe or vessel's actual temperature. The heater is only energized when that line's temperature drops below the thermostat's switching point. When controlling a heater circuit that has both flowing and non-flowing segments, the sensor should be put on the non-flowing branch of the circuit. On critical temperature control processes, separate heater circuits may be required. Advantages of this system include close temperature control and minimum energy usage. Disadvantages are initial control and maintenance costs that will rise in proportion to the number of controllers used.

Ambient Air Control

Ambient control means the heater is turned "off" and "on" depending on the temperature of the surrounding air. This system uses an ambient air sensing thermostat or controller that may turn on an entire panel load of heaters when the air reaches a predetermined temperature (40°F is a typical value). When energizing multiple heater loads, a contactor is used to perform the actual switching. Advantages of ambient control include simplified control wiring and lower control maintenance costs. Disadvantages include loss of precise temperature control and excessive energy consumption (heaters may be on when pipe is being warmed from products flowing through it).

2. Effects of Heat Sinks.

Any thermally conductive material that penetrates through the insulation pulls heat away from the pipe or vessel at a high rate. If extra heater is not installed at these points, the system will be colder in those areas. Self-regulating heaters also require extra cable at those points.

3. Heat-Up Requirements.

Heat loss tables do not include adequate power to provide rapid heat up of pipes or vessels filled with product. If heat-up is required, extra heat must be added. This is often accomplished by using extra heaters that are turned on only in heat-up situations.

4. Hazardous Area Design Criteria.

Heaters installed in hazardous (classified) areas must have sheath temperatures that do not exceed the ignition temperature of the hazardous gas or dust that is present. The method of limiting this temperature varies with different types of products: Self-regulating heaters may be used based on their maximum "T Rating." Under no conditions will the heater cable exceed those temperatures. Constant-wattage heaters and mineral insulated heaters, must be designed not to exceed the ignition temperature. For classified areas, this is achieved by limiting the watt density in the design so the heater's sheath temperature will not exceed the required temperature.

Each heater installed in a hazardous area must have a metal shield or sheath. This provides an effective return ground path as well as providing added physical protection.

All connections and remotely located control equipment should meet the criteria for hazardous area application.

5. Nonmetallic Surfaces

Nonmetallic pipes and vessels often have low softening and melting points. Care must be taken in design not to let the surface or heater reach that temperature. LT and CLT series cables can be used safely without concern. Other cables must use the following precautions:

- Use thermal over limit protection
- Use metal foil tape over and under (sandwiching) the heater cable
- Limit wattage design so cable sheath temperature will not reach the pipe softening point.

6. Designing Self-Regulating Heater Cables for Plastic Pipe

Plastic pipe is not thermally conductive. Although the self-regulating heater cable will itself get hotter in relation to a given pipe temperature, less heat is transferred to plastic pipe than metal pipe. Use Table 8 to determine the correct output of self-regulating heater cable when used on plastic pipe.

There are three methods of applying heater cable to plastic pipe:

- Regular attachment at one foot intervals
 - Attachment of cable at one foot intervals with no heat sinking.
- Foil over the cable
 - Fasten the cable at one-foot intervals (as above) and then cover with a layer of adhesive backed foil tape.
- Foil Over/Under (sandwiched) cable
 - Put a layer of adhesive backed foil tape on the pipe. Fasten the cable over the foil tape per (A) above. Then put another layer of foil tape over the cable.

7. Use of Metal Foil Tape to Lower Sheath Temperature on Metal Pipe

Metal foil tape can be used on all types of heaters to lower sheath temperatures. This should only be done to improve life expectancy. **DO NOT USE THIS TECHNIQUE TO LOWER SHEATH TEMPERATURES FOR DIVISION 1 HAZARDOUS APPLICATIONS.**

8. Temperature “Piling” in Vertical Installations

Heated air and fluid rises. In a vertical piping run, you can expect to see a 1.5 to 3.0 degree C (F) rise per vertical foot of pipe. Temperature control locations and circuit breakup should be used to overcome this temperature control problem.

9. Static vs. Flowing Pipe Fluid Conditions

Heat tracing is needed during stagnant conditions. It is very difficult to freeze or overheat a pipe while product is flowing through it. Most design concerns should center around static situations. For heating of fluids in flowing pipes, consult the factory.

10. Proper Termination and Sealing of Cable Terminations

Cable ends, splices, etc. must be properly sealed to prevent moisture entry. Condensation in junction boxes and rain water leaks in insulation lagging are common moisture sources. Moisture is a primary source of electrical arc failure in heating cable.

11. Foamed/Poured Insulation

When heating cables are to be insulated with foamed, mudded, or poured insulation, the cable should be covered by foil. This is to prevent the cable from being thermally isolated from the pipe. If thermally isolated the cable will not get sufficient heat to the pipe.

12. Wet Insulation/No Insulation

Dry, adequate insulation is a necessity for a pipe heating application. Heat losses are 20 to 50 times greater on wet or uninsulated systems. Water leaks (around valves, hangers and lagging lap joints) will soak the insulation. The heating cable cannot maintain temperatures with wet insulations. Wet insulation will also accelerate corrosion. Once insulation becomes wet, the heating cable will not provide sufficient heat to dry it.

13. Annual System Check-Out

Check your heating system before each freeze season. Process maintenance systems should be on year-round. However, some of the lower maintenance products will not develop a wet insulation “freeze up” until ambient temperatures drop. A system check should verify that all cables are working. Check and repair insulation waterproofing, spot check temperature control function, and whatever else is appropriate to your situation.

Article 427-22 of the National Electrical Code requires ground-fault equipment protection for each branch circuit supplying electric heating equipment. Exceptions to this requirement can be found in the NFPA 70, National Electrical Code.

General Design Considerations

Self-Regulating Heater Cable Output on Plastic Pipe

Power output of a self-regulating heater cable is dependent on its thermal coupling to the pipe. Since all published power output data is calculated with the product on metal pipe, power output must be derated for use on plastic pipe because of its lower thermal coupling. To do this, begin with the required watts/foot value (heat loss) on the vertical axes (W/M (W/Ft) Plastic Pipe) in Table 8. Read across to the curve denoting installation method being used. Read down from this point and find the value on the horizontal axis (W/M (W/Ft) Metal Pipe). This would be the power output if the cable was installed on metal pipe, and is the proper value to use in selecting cable. There are three recommended ways to install self-regulating heater cable on plastic pipe - without foil, with foil and in a foil sandwich. Each has a different thermal coupling rating between the heater cable and the pipe.

Table 1: Self-Limiting Heater Cable Output On Plastic Pipe

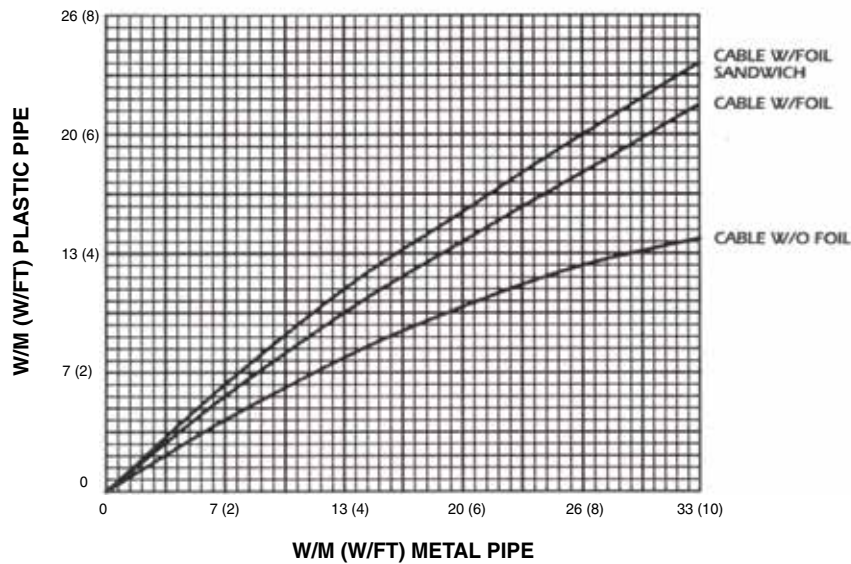

Notes

1. Locate wattage required for plastic pipe on vertical axis of graph.
2. Locate type of installation curve desired.
3. Read horizontal axis to determine correct cable selection

General Design Considerations

There is no one fixed way that is correct to heat a pipe or vessel to the exclusion of all the other methods. However, certain types of heaters lend themselves to specific applications. Our products allow the use of selection criteria based on the best product for the application.

1. Maximum Exposure Temperature

Select the heater type based on the maximum temperature the process will reach. Do not exceed the heater rating. Do not use insulation sandwiching for the use of plastic cables on high temperature steam lines. It will increase installed insulation costs by 50% and is very craft-sensitive. MI Cable should be used instead.

2. Maintain Temperature

Select the heater type based on the maximum process maintenance temperature desired. With thermostatic control, higher temperature heaters can be used to maintain lower temperatures.

3. Heat Requirement

Select the heater type that provides adequate heat output based on your heat loss calculations at minimum ambient. Additional heat output can be achieved with spiraling or multiple heaters, but this often increases cost. Because self-regulating heaters reduce their heat output with increased temperature, their efficiency is reduced at higher maintenance temperatures. MI cable is often a more economical choice at elevated maintenance temperatures.

4. Voltage

Increased voltage provides two advantages, lower amperage and longer circuit lengths. Both decrease power distribution and installation costs

5. Area Classification

Heater type and construction vary with area classification. Nelson offers heater options for all area classifications

6. Ease of Installation

Parallel, self-regulating heaters are normally used for lower temperature applications because they are flexible and can be cut to length in the field. With increased maintenance temperatures or higher heat requirements, the efficiency of self-regulating heaters is reduced, and MI cable often provides the best overall system. Nelson MI cable products are manufactured with high temperature alloy conductors and a thin, high temperature Alloy 825 sheath. They can be overlapped up to 82 w/m (25 w/ft.) and can be formed without the use of special tools.

Table 2: Insulation Factors

Product Family	Maximum Power W/m (W/ft.)	Maximum Voltage	Maximum Maintenance Temperature °C (°F)	Maximum Exposure Temperature °C (°F)
CLT Self-Regulating	26 (8)	277	65 (150)	85 (185)
LT Self-Regulating	33 (10)	277	65 (150)	85 (185)
LLT Self-Regulating	33 (10)	277	65 (150)	85 (185)
HLT Self-Regulating	66 (20)	277	121 (250)	215 (420)
XLT-Self-Regulating	66 (20)	277	150 (300)	230 (450)
NC-Constant-Wattage	39 (12)	277	150 (300)	204 (400)
Custom MI	288 (88)	600	371 (700)	593 (1100)

Application for Table

CLT:	Freeze protection and low temperature maintenance, roof, Gutter de-icing, fire protection systems, non-metallic pipes and tanks for ordinary (unclassified) locations only.
LT:	Freeze protection and low temperature maintenance, roof, Gutter de-icing ^① , fire protection, domestic hot water systems ^② , non-metallic pipes and tanks.
LLT:	Freeze protection and low temperature maintenance, non-metallic pipes.
HLT:	Process maintenance and steam-cleanable freeze protection.
XLT:	Process maintenance and steam-cleanable freeze protection.
NC:	Process maintenance and steam-cleanable freeze protection.
MI:	Applications requiring physical protection, high wattages and/or elevated maintenance and exposure temperatures, metallic pipes and vessels only.

① LT self-regulating cable approved for deicing applications.

② LT-A, B, C, D self-regulating cable approved for domestic hot water maintenance applications.